



# BHL75A

Backhoe Loader



## KEY FEATURES

- Electronically controlled power shift transmission. Reduced operator effort. Uninterrupted power flow.
- The electronically controlled service brake features low pedal pressure and automatic parking brake application when the machine is parked
- Equipped with an efficient load sensing hydraulic system. The pilot controls provide precise operation
- The efficient, strong, high torque engine provides power and responsiveness for both travel and multi-function hydraulic system operation

### Total Weight

7,500 Kg - 16,535lb

### Rated Power

74.4 kW/2,200rpm -  
100hp/2,200rpm

### Bucket Capacity

1.0m<sup>3</sup> - 1.3yd<sup>3</sup>  
0.26m<sup>3</sup> - 0.34yd<sup>3</sup>

### Digging Depth

4,360 mm - 14.3ft

# BHL75A Dimensions & Specifications

## OVERALL DIMENSIONS

	Standard	Metric
A	Transport Length	7381 mm
B	Transport Width	2280 mm
C	Transport Height	3732 mm
D	Cab Height	3129 mm
E	Minimum Ground Clearance (Gear-box)	356 mm
F	Wheelbase	2245 mm
G	Front Wheel Tread Gauge	1775 mm
H	Rear Wheel Tread Gauge	1780 mm
I	Truning Circle (Front Tire Outskirt, Brake)	8500mm
J	Truning Circle (Front Tire Outskirt, No Brake)	9448mm

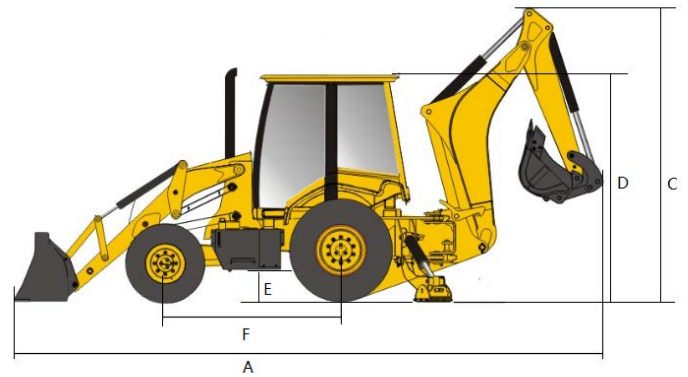

## MACHINE PARAMETERS

Operating Weight	7650 kg
Engine Type	Turbo, Air Charge, Electrice Control
Engine Max Power (Gross)	74kw
Engine Max Torque	410Nm@1600rpm
Engine Displacement	3.6 L
Main Pump Flow	156L/min
Speed Gear 1	5.0 km/h
Speed Gear 2	9 km/h
Speed Gear 3	19 km/h
Speed Gear 4	34 km/h
Max Arm Diggging Force (ISO)	32 kN
Fuel Tank Capacity	140 L
DEF Tank Capacity	10 L
Hydraulic Tank Capacity	120 L
Cooling System Capacity	20 L
Engine Oil Capacity	8.5 L
Gear-box Oil Capacity	18 L

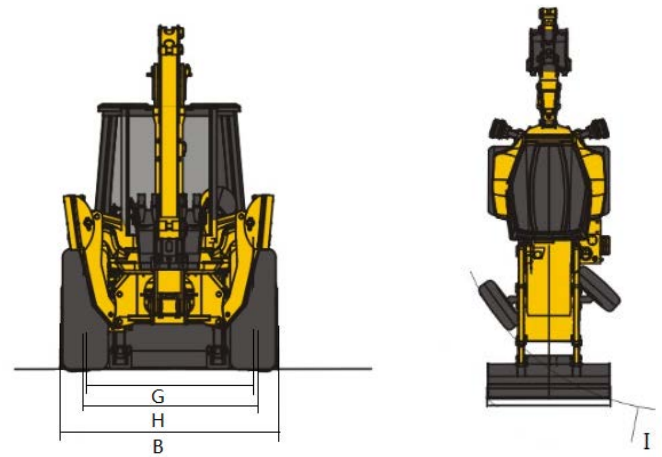

## WORKING RANGE

Backhoe	Standard	Metric
a	Maximum Digging Height	5370 mm
b	Maximum Dumping Height	3560 mm
c	Maximum Digging Depth	4332 mm
d	Maximum Digging Reach	5671 mm
e	Minimum Swing Radius	2099 mm
Loader		
f	Maximum Hinge Pin Height	3478 mm
g	Dump Angle at Full Height	43°
h	Dump Height at Maximum Angle	2742 mm
i	Dump Reach at Maximum Angle	849 mm

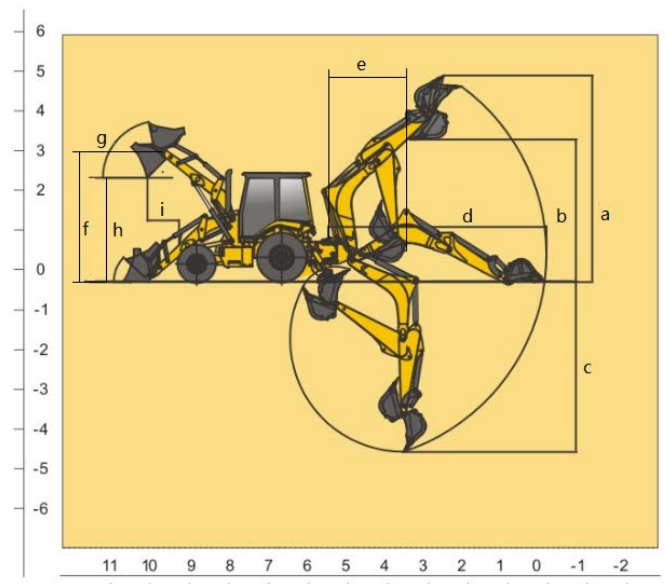

### SANY America Inc.

318 Cooper Circle | Peachtree City, GA 30269  
T: 678-251-2810 | F: 770-632-7820

[www.sanyamerica.com](http://www.sanyamerica.com)

